

ABSOLUTELY NO CLAIMS OR WARRANTIES OF ANY KIND ARE EXPRESSED OR IMPLIED AS TO THE ACCURACY OR SUITABILITY OF THIS DIAGRAM FOR ANY PURPOSE WHATSOEVER. THE USER OF THIS INFORMATION ACCEPTS ALL RESPONSIBILITY FOR THE CONSEQUENCES OF ITS USE.

© 2005-PRESENT SLOCLONE FORUMS. ANY DISTRIBUTION WITHOUT EXPRESSED WRITTEN CONSENT IS PROHIBITED. THE SLOCLONE FORUMS ARE IN NO WAY AFFILIATED WITH SOLDANO CUSTOM AMPLIFICATION®, MICHAEL SOLDANO JR., OR SUPER LEAD 100 OVERDRIVE™.

SLOCLONE SCHEMATIC PREAMP & POWER AMP

Design: SLOCLONE FORUMS

Drawn By: JED
VERSION 1.8

Scale: NTS

Sheet 1 OF 2

*** NOTES**

1. INSTALL SWITCH 3 FOR "WARREN HAYNES" MOD.
2. INSTALL C13 AND R50 TO REDUCE SEND LEVEL TO 0dB.
3. INSTALL LDR5 TO DECREASE BLEED FROM THE CLEAN/CRUNCH CHANNEL INTO THE OD CHANNEL. THE PREAMP PCB BOARD WILL NEED TO BE MODIFIED.
4. INSTALL C23, C24, AND VR9 FOR THE "DEPTH" MOD.
5. INSTALL R48 AND R49 FOR BIAS MEASUREMENT.
6. INCREASE R44-R47 TO 1K-5W IF USING KT66 OR EL34 TUBES (R45 AND R47 NOT INCLUDED IN 50 WATT VERSION)
7. INCREASE R40-R43 TO 5.6K IF USING KT66 OR EL34 TUBES (R41 AND 43 NOT INCLUDED IN 50 WATT VERSION).
8. GROUND BOTH ENDS OF THE FX SEND WIRE. THIS IS THE GROUND WIRE FOR THE FX LOOP JACKS.

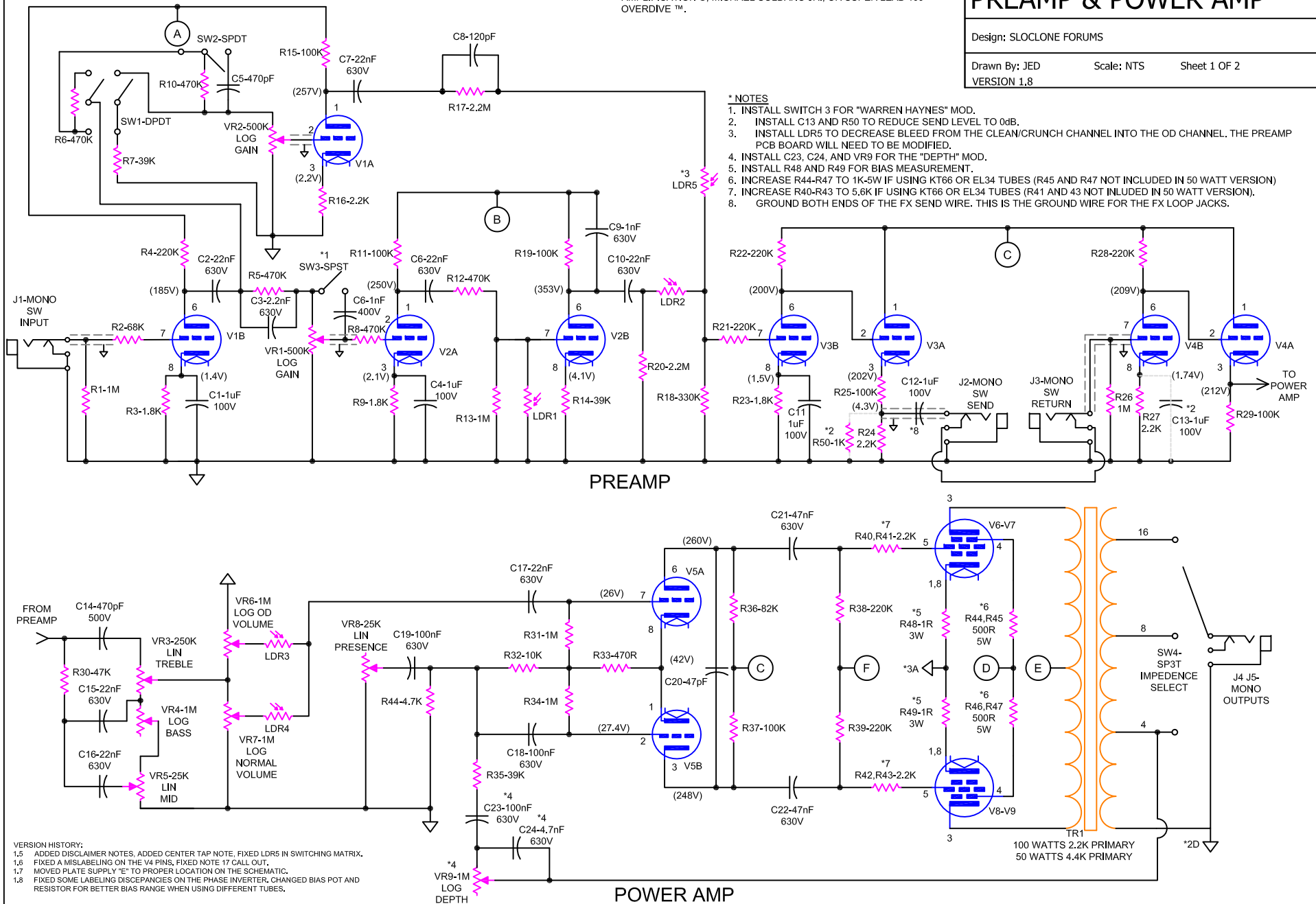

PREAMP

POWER AMP

VERSION HISTORY:

- 1.5 ADDED DISCLAIMER NOTES, ADDED CENTER TAP NOTE, FIXED LDR5 IN SWITCHING MATRIX.
- 1.6 FIXED A MISLABELING ON THE V4 PINS, FIXED NOTE 17 CALL OUT.
- 1.7 MOVED PLATE SUPPLY "E" TO PROPER LOCATION ON THE SCHEMATIC.
- 1.8 FIXED SOME LABELING DISCREPANCIES ON THE PHASE INVERTER, CHANGED BIAS POT AND RESISTOR FOR BETTER BIAS RANGE WHEN USING DIFFERENT TUBES.

ABSOLUTELY NO CLAIMS OR WARRANTIES OF ANY KIND ARE EXPRESSED OR IMPLIED AS TO THE ACCURACY OR SUITABILITY OF THIS DIAGRAM FOR ANY PURPOSE WHATSOEVER. THE USER OF THIS INFORMATION ACCEPTS ALL RESPONSIBILITY FOR THE CONSEQUENCES OF ITS USE.

© 2005-PRESENT SLOCLONE FORUMS. ANY DISTRIBUTION WITHOUT EXPRESSED WRITTEN CONSENT IS PROHIBITED. THE SLOCLONE FORUMS ARE IN NO WAY AFFILIATED WITH SOLDANO CUSTOM AMPLIFICATION®, MICHAEL SOLDANO JR., OR SUPER LEAD 100 OVERDIVE™.

SLOCLONE SCHEMATIC POWER SUPPLY

Design: SLOCLONE FORUMS

Drawn By: JED

Scale: NTS

Sheet 2 OF 2

VERSION 1.8

*** NOTES**

9. IF TAKING FROM THE HV TAP MAKE R67 220K 1W. OTHERWISE, ADJUST TO MAKE IDLE CURRENT BETWEEN 20mA AND 45mA.
10. R53 MAY ALSO BE ADJUSTED TO GET CORRECT IDLE CURRENT. 56K IN THE ORIGINAL.
11. IF USING 220V-240V MAINS LOWER F1 TO 2.5A SLO OR 1.5A SLO DEPENDING ON DESIRED WATTAGE.
12. ADD R59, R60, AND C36 FOR AN ELEVATED DC HEATER REFERENCE IN ORDER TO REDUCE HUM OTHERWISE GROUND CENTER TAP OR 100 OHM RESISTORS TO MAIN GROUND BUSS.
13. REDUCE R64 TO 33R IF ADDING LDR5. SEE ALSO NOTE 3 SHEET 1 OF 2.
14. REDUCE R61 TO 5R OR REMOVE IT IF USING A 5V TAP.
15. 10uF/100V IN THE ORIGINAL SLO-100.
16. SWITCHING SUPPLY IS GROUNDED TO CHASSIS AT FOOTSWITCH JACK.
17. IF PT DOES NOT HAVE A CENTER TAP USE TWO-100R 1 WATT RESISTORS AS A *FAUX CENTER TAP.
18. 25K IN THE ORIGINAL.

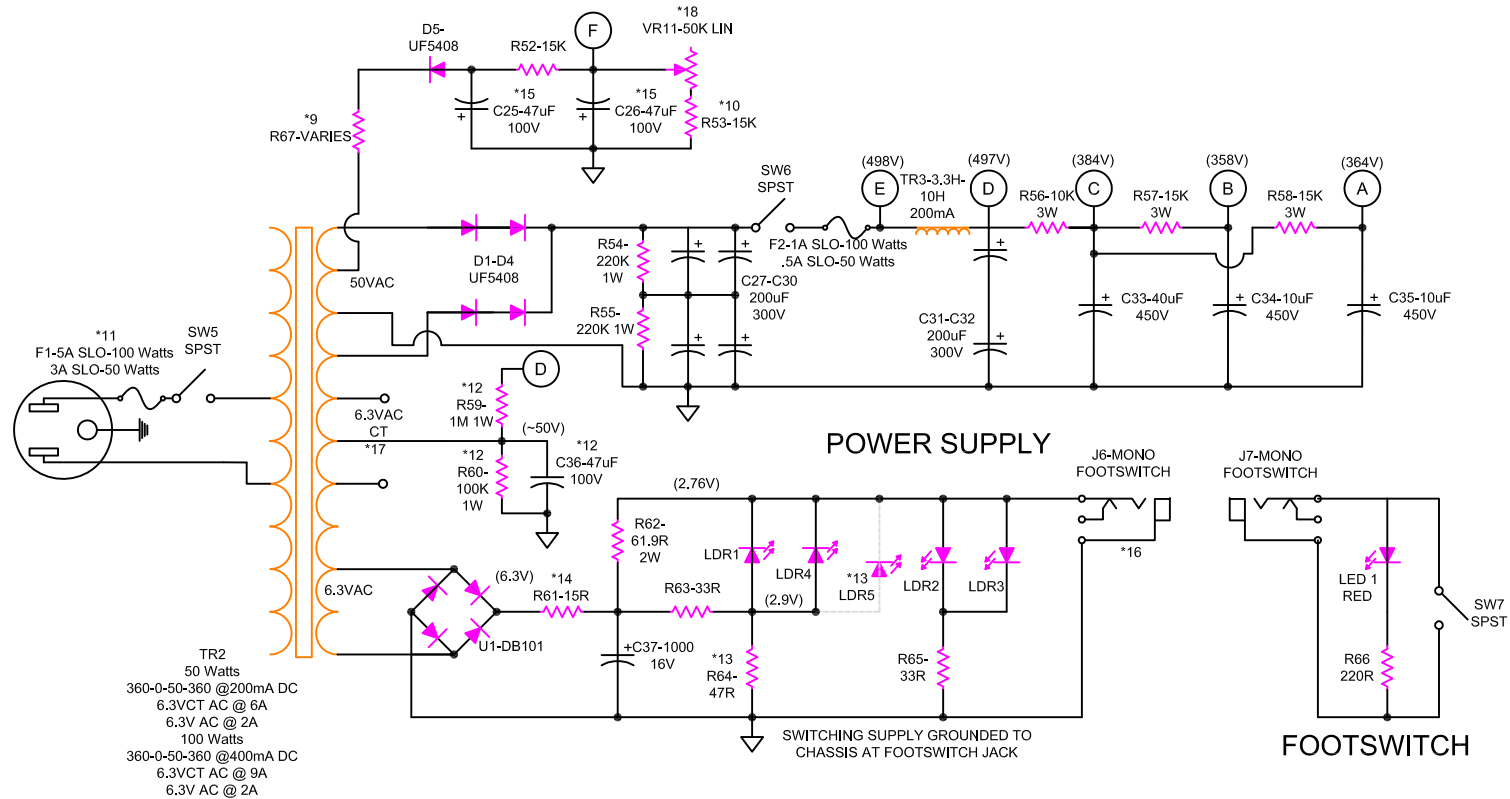

VERSION HISTORY:
 1.5 ADDED DISCLAIMER NOTES, ADDED CENTER TAP NOTE, FIXED LDR5 IN SWITCHING MATRIX.
 1.6 FIXED A MISLABELING ON THE V4 PINS, FIXED NOTE 17 CALL OUT.
 1.7 MOVED PLATE SUPPLY "E" TO PROPER LOCATION ON THE SCHEMATIC.
 1.8 FIXED SOME LABELING DISCREPANCIES ON THE PHASE INVERTER, CHANGED BIAS POT AND RESISTOR FOR BETTER BIAS RANGE WHEN USING DIFFERENT TUBES.